

EUTIT, s.r.o.

I. N.: 47714930

Stará Voda 196

phone: +420 / 354 789122, +420 / 354 691301

CZ - 353 01 Mariánské Lázně

fax: +420 / 354 691480

e-mail: eutit@eutit.cz <http://www.eutit.cz>

A. CHARACTERISTIC

Cast basalt, i. e. products of this material, are castings produced by melting, reshaping and cooling of suitable natural rocks, especially olivine basalts. Under this marking a wide assortment of tiles (including anti-sliding ones), pipes (inserts), adapting pipes and other special castings is produced. These products are distinguished for their high abrasion resistance, chemical resistance, they are not liquid-absorbing and they have a considerable compression strength.

Use: multilateral

Tiles: floors of interiors, especially of historical buildings, but also of hotel halls, restaurants, motor shows, very mechanically loaded floors of industrial buildings including exteriors; floors resistant to chemical agents, oil products etc.

Pipes (inserts): suitable for hydraulic and pneumatic stowing and in general for transport of variety of abrasive materials.

Special castings (bends, branch pipes, T-sections, Y-sections as additions of piping orders, grate rolls, jets, cyclones etc.) as

replacement of parts of high-alloy steel;

In general we can say that casted basalt has 5 - 20 higher abrasion resistance than special alloyed cast iron and steel.

Evaluation: Certificates of products No. 03 – 8933, No. 03 – 8934
issued on 1. 12. 1998

EUTIT, s.r.o.

I. N.: 47714930

Stará Voda 196

phone: +420 / 354 789122, +420 / 354 691301

CZ - 353 01 Mariánské Lázně

fax: +420 / 354 691480

e-mail: eutit@eutit.cz<http://www.eutit.cz>

B. TECHNICAL DATA (MEAN VALUES)

1. Basic properties

Mohs hardness (ČSN EN 101)	: min. degree 8 ⁺
Volume mass (ČSN EN 993-1)	: 2900 - 3000 kg.m ³
Water absorption (ČSN EN ISO 10545-3)	: 0 %
Compression strength (ČSN EN 993-5)	: min. 300 - 450 MPa ⁺⁺
Bending strength (ČSN EN 993-6)	: min. 45 MPa
Coefficient of linear thermal expansion	
0 - 100°C (ČSN EN ISO 10545-8)	: max. 8.10 ⁻⁶ K ⁻¹
0 - 400°C (ČSN EN ISO 10545-8)	: max. 9.10 ⁻⁶ K ⁻¹
Sulphuric acid solubility (ČSN EN 993-16)	: max. 9 % of mass
Sodium hydroxide insolubility (ČSN 72 5122)	: min. 98,6 % of mass
Abradability (DIN 52108)	: max. loss 5 cm ³ /50 cm ²
Resistance to deep abrasion (ČSN EN ISO 10545-6)	: max. loss 110 mm ³
Heat shock resistance (DIN 52313)	: min. 150°C
Frost resistance (ČSN EN ISO 10545-12)	: min. 50 cycles at -15 +15°C

⁺ Diamond has the hardness according Mohs 10⁺⁺ The found-out data were obtained in the samples of material and because basalt is a natural material, these values need not be always measured in other samples or in products of other shapes and dimensions.

2. Other properties

Apparent porosity (ČSN EN 993-1)	: 0 % of volume
Thermal conductivity (ČSN EN 993-14)	: 1,9 - 2,2 Wm ⁻¹ K ⁻¹ in range of temperature 20 - 1000°C
Modulus of elasticity (procedure per par 13 of ON 70 1807/67)	: min. 11.10 ⁴ MPa
Insulation resistance (ČSN 34 1382)	: max. 10 ¹⁰ Ω
Antisliding capability of tiles (DIN 51130)	: R 10 (angle value 10-19° - smooth tiles) R 11 (angle value 19-27° - relief tiles)
Radioactivity Ra ²²⁶	: 13,1 ± 2,4 Bq.kg ⁻¹
Th ²²⁸	: 20,8 ± 3,4 Bq.kg ⁻¹
Vickers hardness (EN ISO 6507-1)	: 700 - 800 HV (MPa)

Mineralogical composition

Basic minerals of cast basalt are monoclinic and rhombic pyroxenes, spherulitic and dendritic structures. In addition to these minerals cast basalt also contains a small amount of magnetite, olivine and residual vitreous phase.

EUTIT, s.r.o.

I. N.: 47714930

Stará Voda 196

phone: +420 / 354 789122, +420 / 354 691301

CZ - 353 01 Mariánské Lázně

fax: +420 / 354 691480

e-mail: eutit@eutit.cz<http://www.eutit.cz>**Heat resistance**

By experience cast basalt can be used up to 400°C unless it is chemically corrosive ambient and without occurrence of larger thermal fluctuation. A slow heating up to operating temperature is also necessary.

Comparison with DIN 28062

Basic properties and their values			
Parameter	Unit	Value	DIN 28062
Mohs hardness	degree	8	+
Volume mass	kg.m ⁻³	2800 - 2900	2800 - 2900
Compression strength	MPa	300 - 450	450 bis 550
Bending strength	MPa	45	30
Coefficient of linear thermal expansivity	0 - 100°C K ⁻¹	8.10 ⁻⁶	6 - 8.10 ⁻⁶
	0 - 400°C K ⁻¹	9.10 ⁻⁶	+
Abradability	cm ³ /50 cm ²	max. 5	4 - 6
Resistance to deep abrasion	mm ³	110	+
Absorbtion capacity	mass - %	0	0
Apparent porosity	Volume - %	0	+
Modulus of elasticity	MPa	11.10 ⁴	10 - 12.10 ⁴
Thermal conductivity	W.m ⁻¹ .K ⁻¹	1,9 - 2,2	1,0 - 1,2
Thermal shocks resistance	°C	100	+
Sulphuric acid solubility	Volume - %	9	+++
Insulation resistance	Ω	10 ¹⁰	+

+ This value is not stated in the DIN standard. (Diamond has the hardness according to Mohs 10).

++ DIN 28062 states applicability value 300°C in chemical production of instruments under usual hydrothermal conditions. Based on our experience cast basalt can be used up to 500°C unless it is chemically corrosive environment and unless a larger thermal fluctuation occurs. A slow heating up to operating temperature is also necessary (approximately 60°C/hour).

+++ Per DIN 28062 the value is different according to the type of rock and occurrence. Cast basalt is well resistant to all organic solvents and acids. It is also well resistant to alkaline solutions including inorganic ones. From inorganic acids except for hydrofluoric acid, which dissolves it just as each silicate, hydrochloric acid is the most corrosive. It always considerably depends on concentration of acting medium and mainly on temperature with whose rise chemical resistance of cast basalt considerably drops. Mixtures of particular agents also affect it. In particular case we recommend to carry out at least orientation



**Cast basalt
CATALOGUE SHEET**

E-01

EUTIT, s.r.o.

I. N.: 47714930

Stará Voda 196

phone: +420 / 354 789122, +420 / 354 691301

CZ - 353 01 Mariánské Lázně

fax: +420 / 354 691480

e-mail: eutit@eutit.cz <http://www.eutit.cz>

laboratory test.

EUTIT, s.r.o.

I. N.: 47714930

Stará Voda 196

phone: +420 / 354 789122, +420 / 354 691301

CZ - 353 01 Mariánské Lázně

fax: +420 / 354 691480

e-mail: eutit@eutit.cz<http://www.eutit.cz>

Comparison of basic operating properties of basalt with some other materials (mean values):

Property	Ceramic tiling elements	Concrete tiles	Basalt tiles
Abrasion resistance [cm ³ /50 cm ²] [mm ³]	6 - 10 140 - 200	19 - 24 440 - 580	5 110
Bending strength [MPa]	30 - 60	5 - 7	45
Compression strength [MPa]	110 - 190	20 - 40	300 - 450
Chemical resistance	high	low	high
Frost resistance	frostproof	frostproof	frostproof

The values of Vickers hardness considerably exceed hardness of wear resistant cast irons and steels and they are comparable with high-grade, hardened and tempered steels with tensile strength in the range of about 2300 - 2600 MPa.

C. SUPPLIER AND COMMERCIAL DATA

Manufacturer guarantees basic technical data according to this catalogue sheet. In case of need execution of the tests can be agreed according to respective standards.

Ordering:

During the order the following data must be agreed:

- designation of manufacturer
- type and size of product
- number of pc
- delivery term
- total mass

Packaging: The products are as a rule transported on pallets (banded, in foils) or as carload consignments freely deposited in covered transport means. As a protective interlined material the polystyrene, paper, sawn timber or other suitable material are used.

Size and point of view of surface quality for particular products are stated in supplements of this catalogue sheet.

EUTIT, s.r.o.

I. N.: 47714930

Stará Voda 196

phone: +420 / 354 789122, +420 / 354 691301

353 01 Mariánské Lázně

fax: +420 / 354 691480

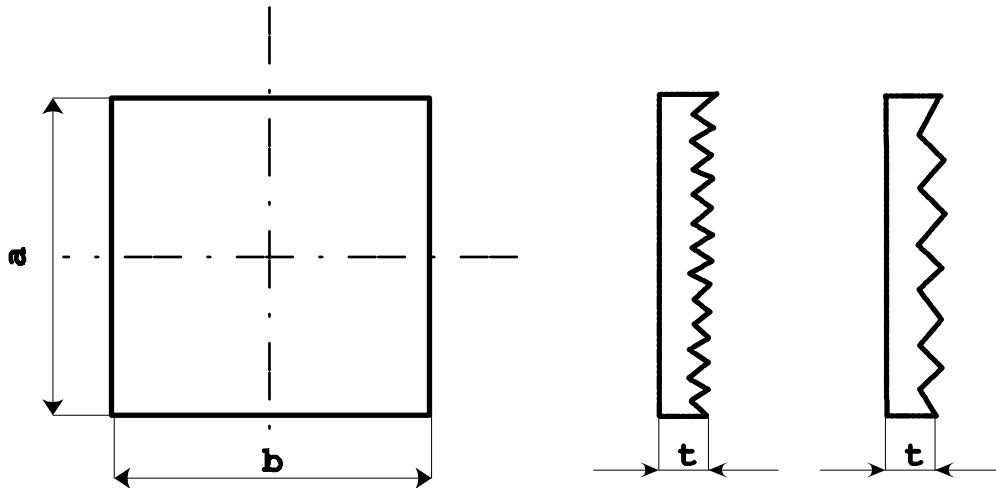
e-mail: eutit@eutit.cz<http://www.eutit.cz>

Picture 1 - rectangular tiles

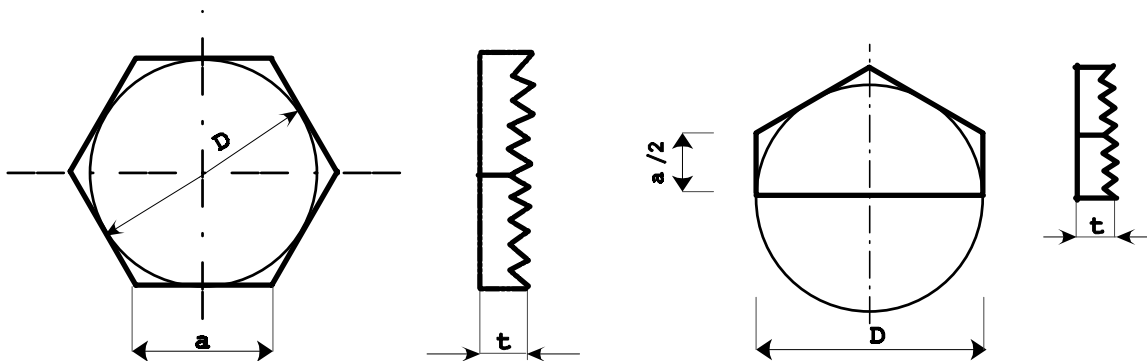

Picture 2 - hexagonal tiles

Picture 3 - shape A

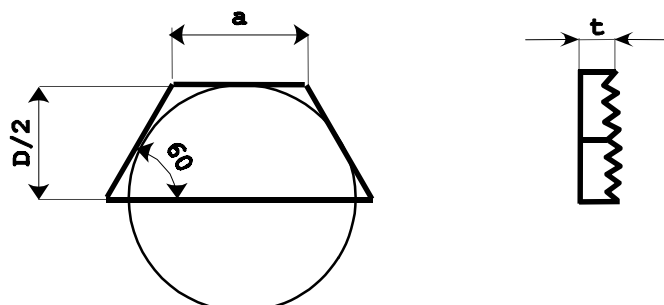

Picture 4 - shape B

EUTIT, s.r.o.

I. N.: 47714930

Stará Voda 196

phone: +420 / 354 789122, +420 / 354 691301

353 01 Mariánské Lázně

fax: +420 / 354 691480

e-mail: eutit@eutit.cz <http://www.eutit.cz>

Dimensions in mm

Table 1. RECTANGULAR TILES

Indication	Side length		Thickness	
	a ± 2	b ± 2	t*	
200/100/22JR	200	100	22	±2
200/100/30H	200	100	30	±2
200/100/30JR			30	
200/100/30R			30	
200/100/40H	200	100	40	±2
200/100/40JR			40	
200/100/40R			40	
200/200/22H	200	200	22	±2
200/200/22JR			22	
200/200/25H	200	200	25	±2
200/200/25JR			25	
200/200/25R			25	
200/200/30H	200	200	30	±2
200/200/30JR			30	
200/200/30R			30	
200/200/40H	200	200	40	±2
200/200/40JR			40	
200/200/40R			40	
200/200/50H	200	200	50	±2
200/200/50JR			50	
200/200/50R			50	
200/200/60R	200	200	60	±3
250/125/30H	250	125	30	±2
250/125/30JR			30	
250/125/30R			30	
250/125/40H	250	125	40	±2
250/125/40R			40	
250/250/25JR	250	250	25	±2
250/250/30H	250	250	30	±2
250/250/30JR			30	
250/250/30R			30	
250/250/40R	250	250	40	±2
250/250/50R	250	250	50	±2

* For grooved tiles it is wall thickness including grooving.

R – coarse grooving

JR – fine grooving

H – glost, grooving free

The maximum deviation from flatness centre curvature, related to diagonal, edge curvature related to the corresponding work size and warpage, related to diagonal is ±2 mm (see EN 98).

EUTIT, s.r.o.

I. N.: 47714930

Stará Voda 196

phone: +420 / 354 789122, +420 / 354 691301

353 01 Mariánské Lázně

fax: +420 / 354 691480

e-mail: eutit@eutit.cz<http://www.eutit.cz>

Dimensions in mm

Table 2. HEXAGONAL TILES

Indication		SHAPE B		SHAPE A		t	Number pc/m ² whole/half ones
		D	D/2	a	a/2		
total	half	± 2	± 2	± 2	± 2	*	
200/25R	200/25R					25	
200/30R	200/30R					30	
200/40R	200/40R	200	100	115,5	57,7	40	±2
200/50R	200/50R					50	
200/60R	200/60R					60	±3
250/30R	250/30R	250	125	144,3	72,1	30	±2
250/40R	250/40R					40	

* For grooved tiles it is wall thickness including grooving.

R – coarse grooving

The maximum deviation from flatness centre curvature, related to diagonal, edge curvature related to the corresponding work size and warpage, related to diagonal is ± 2 mm (see EN 98).

1. The tiles are manufactured and supplied particularly in the version:

a) rectangular

aa) total - see Fig. 1 and Tab. 1,

ab) half - 200 x 100 mm; thickness 30, 40, 50 mm

b) hexagonal

ba) total - see Fig. 2 and Tab. 2,

bb) half - see Fig. 3 and Tab. 2.

2. Half rectangular and hexagonal tiles are used as additions for laying of paving or tiling on the edges.

3. In case where for technical reasons different forms and dimensions are required than it is stated in the tab. 1 and 2, after agreement between manufacturer and customer the tiles of various ground plans and thickness, possibly also with grooves can be supplied.

4. The tiles are indicated:

a) square - by length of sides and wall thickness,

b) hexagonal - by diameter of inscribed circle and by wall thickness.

5. Technical requirements for the order:

a) indication,

b) requirement for plain version or version with grooves.



EUTIT, s.r.o.

I. N.: 47714930

Stará Voda 196

phone: +420 / 354 789122, +420 / 354 691301

353 01 Mariánské Lázně

fax: +420 / 354 691480

e-mail: eutit@eutit.cz <http://www.eutit.cz>

6. Approx. weight of the product is calculated from volume weight 2960 kg.m^{-3} . This mass is only approximate, because the actual mass can differ within the bend of standardised tolerances for dimensions. With grooved tiles also the shape of the groove influences the weight. The weights of tiles produced as standard ones vary approximately between 1,3 kg – 7,2 kg (tiles with the thickness of the wall of 60 mm).

7. Common provisions - Catalogue sheet No. E - 01

8. Surface quality

Basalt products must have a clear sound, they must not have defects, which could affect their function during the use determined. Cracks of basalt products are identified by hammering (weight of hammer approx. 0,3 kg), the product without cracks must produce a clear sound.

9. At least 95 % of products must not have visible defects, which could affect surface quality of the tiles (see EN ISO 10545-2) and they must meet requirements for sampling (principal see EN ISO 10545-1).

EUTIT, s.r.o.

I. N.: 47714930

Stará Voda 196

phone: +420 / 354 789122, +420 / 354 691301

353 01 Mariánské Lázně

fax: +420 / 354 691480

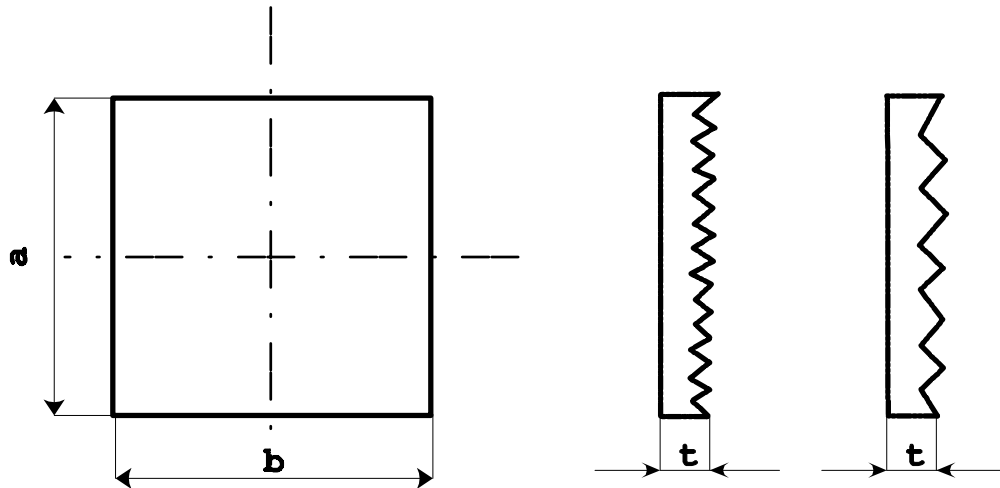
e-mail: eutit@eutit.cz<http://www.eutit.cz>

Picture 1 - rectangular tiles

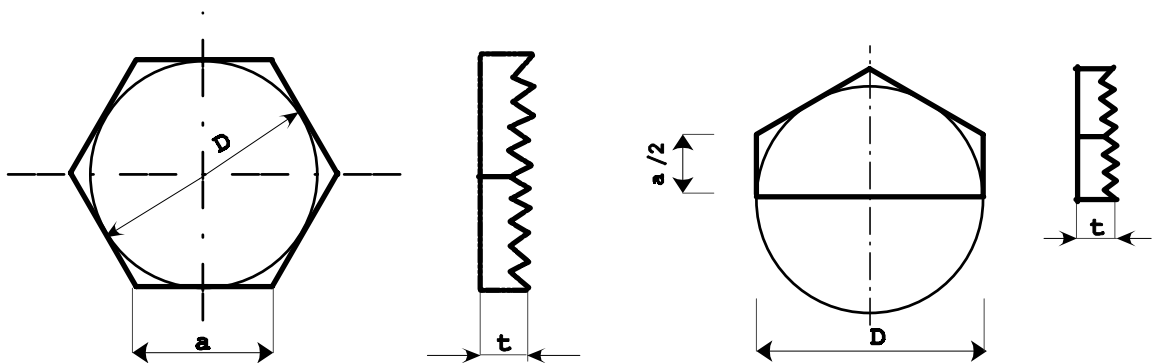

Picture 2 - hexagonal tiles

Picture 3 - shape A

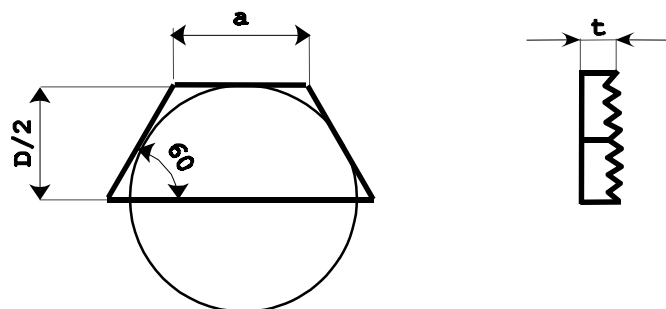

Picture 4 - shape B

EUTIT, s.r.o.

I. N.: 47714930

Stará Voda 196

phone: +420 / 354 789122, +420 / 354 691301

353 01 Mariánské Lázně

fax: +420 / 354 691480

e-mail: eutit@eutit.cz<http://www.eutit.cz>

Dimensions in mm

Table 1. RECTANGULAR TILES

Indication	Side length		Thickness	Number of pc in m ²
	a ± 2	b ± 2	t*	
200/200/22JR 200/200/30JR	200	200	22 ±2 30 ±2	25
250/250/22JR 250/250/30JR	250	250	22 ±2 30 ±2	16

* For grooved tiles it is wall thickness including grooving.

JR – fine grooving

In addition to these basic types after agreement with customer it is also possible to supply other tiles with various surface hue as a.g. FLORENTINA, MAVA etc.

The maximum deviation from flatness centre curvature, related to diagonal, edge curvature related to the corresponding work size and warpage, related to diagonal is je ±2 mm (see EN 98).

Dimensions in mm

Table 2. HEXAGONAL TILES

Indication		SHAPE B		SHAPE A		t	Number pc/m ² whole/half ones
		D	D/2	a	a/2		
total	half	± 2	± 2	± 2	± 2	*	
200/30JR	200/30JR	200	100	115,5	57,7	30 ±2	29/58

* For grooved tiles it is wall thickness including grooving.

JR – fine grooving

The maximum deviation from flatness centre curvature, related to diagonal, edge curvature related to the corresponding work size and warpage, related to diagonal is je ±2 mm (see EN 98).

1. The tiles are manufactured and supplied particularly in the version:

a) rectangular

aa) total - see Fig. 1 and Tab. 1,

ab) half - 200 x 100 mm; thickness 30, 40, 50 mm

b) hexagonal

ba) total - see Fig. 2 and Tab. 2,

bb) half - see Fig. 3 and Tab. 2.

2. Half rectangular and hexagonal tiles are used as additions for laying of paving or tiling on the edges.

EUTIT, s.r.o.

I. N.: 47714930

Stará Voda 196

phone: +420 / 354 789122, +420 / 354 691301

353 01 Mariánské Lázně

fax: +420 / 354 691480

e-mail: eutit@eutit.cz <http://www.eutit.cz>

3. In case where for technical reasons different forms and dimensions are required than it is stated in the tab. 1 and 2, after agreement between manufacturer and customer the tiles of various ground plans and thickness, possibly also with grooves can be supplied.
4. The tiles are indicated:
- square - by length of sides and wall thickness,
 - hexagonal - by diameter of inscribed circle and wall thickness.
5. Technical requirements for the order:
- indication,
 - requirement for plain version or version with grooves.
6. Approx. weight of the product is calculated from volume weight $2960 \text{ kg}\cdot\text{m}^{-3}$. This mass is only approximate, because the actual mass can differ within the bend of standardised tolerances for dimensions. With grooved tiles also the shape of the groove influences the weight. The weights of tiles produced as standard ones vary approximately from 1,3 kg (tiles 200/100/22 mm) to 5,6 kg (tiles 250/250/30 mm).
7. Common provisions - Catalogue sheet No. E - 01
8. Surface quality
- 8.1. Basalt products must have a clear sound, they must not have defects, which could affect their function during the use determined. Cracks of basalt products are identified by hammering (weight of hammer approx. 0,3 kg), the product without cracks must produce a clear sound.
- 8.2. Working surface of interior tiles must correspond with the following description:
At periphery of working surface the surface mostly has characteristic bright blue-black hue. The central part of the surface is matte and it is coloured grey-red - grey-black, this „stain“ has an irregular form and various size. Between two parts of the tile surface, whose colour considerably differs, there is as a rule transition zone of a matte grey-green hue, which can locally be replaced by iridescent hue.
- 8.3. Evaluation of surface quality
The tested tiles are deposited in such a way that the evaluated surface will be evaluated from the distance 2 m. The evaluated surfaces of the tiles are evaluated for intensity of uniformly diffused light 300 lx; the intensity of lighting is measured in the centre and in all corners of the tiles tested.
The tiles are evaluated by a naked eye (glasses, if the evaluating person is used to wear them). The preparation of tested surface and the observation must not be carried out by the same person. Intentional surface effects are not considered a defect.



**Cast basalt
Interior tiles**

P-2

EUTIT, s.r.o.

I. N.: 47714930

Stará Voda 196

phone: +420 / 354 789122, +420 / 354 691301

353 01 Mariánské Lázně

fax: +420 / 354 691480

e-mail: eutit@eutit.cz <http://www.eutit.cz>

9. At least 95 % of products must not have visible defects, which could affect surface quality of the tiles (see EN ISO 10545-2) and they must meet requirements for sampling (principal see EN ISO 10545-1).

EUTIT, s.r.o.

I. N.: 47714930

Stará Voda 196

phone: +420 / 354 789122, +420 / 354 691301

353 01 Mariánské Lázně

fax: +420 / 354 691480

e-mail: eutit@eutit.cz

<http://www.eutit.cz>

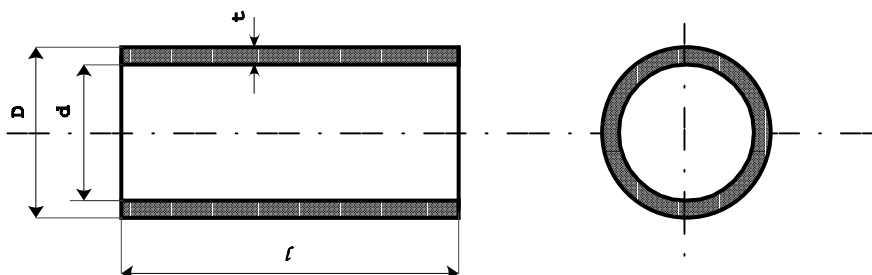

Fig. 1

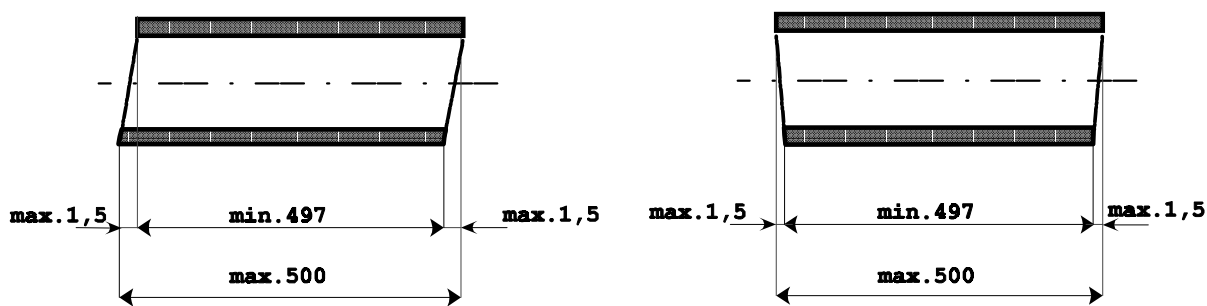

Fig. 2

Dimensions in mm **Table 1. TUBES (INSERTS) – STATICALLY CASTING**

Indication	$d \pm 2$	$D \pm 2$	t (cca)	l +2/-4
82,5	82,5	122,5	25	500

Dimensions in mm **Table 2. TUBES (INSERTS) – SPUN CASTING**

Indication	d	D	t (cca)	l +2/-4
100	100 ±4,5	140 +1/-3	20	500
125	125 ±3	165 +1/-3		
150	150 ±3	190 +1/-3		
175	175 ±3	215 +1/-3		
204	204 ±3	244 +2/-3		
225	225 ±3	265 +2/-3		
254	254 ±3	294 +2/-3		
303	303 ±3	343 +2/-4		
356	356 ±3	396 +2/-4		
400	400 ±3	440 ±4		
456	456 ±3	496 ±4	23	
500	500 ±3	546 ±4	23	
600	600 ±3	646 ±4	23	
610	610 ±3	656 ±4	23	

	Cast basalt	P-3
	Tubes (inserts) of cast basalt, statically and spun casting	
EUTIT, s.r.o.	I. N.: 47714930	
Stará Voda 196	phone: +420 / 354 789122, +420 / 354 691301	
353 01 Mariánské Lázně	fax: +420 / 354 691480	
	e-mail: eutit@eutit.cz	http://www.eutit.cz

Table 3. INDICATION AND CLASSIFICATION OF INSERTS

Indication	Colour					
	red		green		blue	
	Inside diameter					
	d_a		d_b		d_c	
100	97	$\pm 1,5$	100	$\pm 1,5$	103	$\pm 1,5$
125	123		125		127	
150	148		150		152	
175	173		175		177	
204	202		204		206	
225	223		225		227	
254	252	± 1	254	± 1	256	± 1
303	301		303		305	
356	354		356		358	
400	398		400		402	
456	454		456		458	
500	498		500		502	
600			600	± 3		
610			610	± 3		

In addition to the stated inner diameters after agreement with customer also other arbitrary inner diameters in the stated range Js 100 - 610 mm spun casted or also smaller inner diameters casted statically can be manufactured.

1. Basalt inserts are manufactured:
 - a) statically casting - see Fig. 1 and Tab. 1,
 - b) spun casting - see Fig. 1 and Tab. 2
2. Ovality (out-of-roundness) is defined within the limit tolerances of inside diameter classification according to table No. 3.
3. Deviations of perpendicularity of front surfaces from axis are defined within limit tolerances - see Fig. 2.
4. Spun casted inserts are classified into three groups according to size of inside diameters stated in the tab. 3.
Particular groups are indicated with a respective colour by manufacturer.



EUTIT, s.r.o.

Stará Voda 196

353 01 Mariánské Lázně

I. N.: 47714930

phone: +420 / 354 789122, +420 / 354 691301

fax: +420 / 354 691480

e-mail: eutit@eutit.cz <http://www.eutit.cz>

5. The mass of the products is calculated from the volume weight of $2960 \text{ kg}\cdot\text{m}^{-3}$ according to the formula $M = 9,3 \cdot 10^{-6} \cdot l \cdot t \cdot (d+t)$. This mass is only approximate, because the actual mass can differ within the bend of standardised tolerances for dimensions. If we take into consideration the ordinary range of products (see table No.2 on p.12) the mass can range from 11.2 kg to 56 kg (a pipe of $d=500\text{mm}$).
6. Technical requirements of the order:
indication (for the indication the value of inside diameter d is used).
7. Common provisions - Catalogue sheet No. E - 01
8. Surface quality
Basalt products must have a clear sound, they must not have defects, which could affect their function during the use determined.
9. At least 95 % of products must not have visible defects, which could affect surface quality of the tiles and they must meet requirements for sampling (principal see EN ISO 10545-1).

EUTIT, s.r.o.

Stará Voda 196

353 01 Mariánské Lázně

I. N.: 47714930

phone: +420 / 354 789122, +420 / 354 691301

fax: +420 / 354 691480

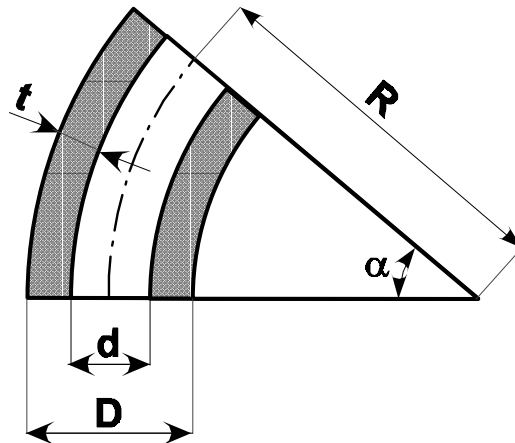
e-mail: eutit@eutit.cz <http://www.eutit.cz>**A. BENDS****Fig. 1**

In the order for arches with inside diameter $d = 100$ mm and with outside diameter $D = 132,5$ mm for radius $R = 750$ mm and wall thickness $t = 25$ mm at central angle $\alpha = 30^\circ$ is indicated:

Bend 100 / 750 / 30 of cast basalt

EUTIT, s.r.o.

I. N.: 47714930

Stará Voda 196

phone: +420 / 354 789122, +420 / 354 691301

353 01 Mariánské Lázně

fax: +420 / 354 691480

e-mail: eutit@eutit.cz <http://www.eutit.cz>

Table 1 - BENDS

Indication (d x R x alfa)	d (mm)		D (mm)		t (mm)	alfa		R (mm)
	nominal value	limit tolerance s	nominal value	limit tolerance s		nominal value	* limit tolerances mm	
82,5/750/15	82,5	± 2	132,5	± 3	23-27	15	± 3	750
82,5/750/30						30		750
82,5/1000/15						15		1000
82,5/1000/30						30		1000 ± 1 %
82,5/1500/15						15		1500
82,5/2000/15						15		2000
82,5/2500/7,5						7,5		2500
82,5/3000/7,5						7,5		3000
100/750/15	100,0	+2/-3	150,0	+3/-2	23-27	15	± 3	750
100/750/30						30		750
100/1000/15						15		1000
100/1000/30						30		1000 ± 1 %
100/1500/15						15		1500
100/2000/15						15		2000
100/2500/7,5						7,5		2500
100/3000/7,5						7,5		3000
125/750/15	125,0	+2/-3	175,0	+3/-2	23-27	15	± 3	750
125/750/30						30		750
125/1000/15						15		1000
125/1000/30						30		1000 ± 1 %
125/1500/15						15		1500
125/2000/15						15		2000
125/2500/7,5						7,5		2500
125/3000/7,5						7,5		3000

* The tolerance of the limiting deviation „alfa“ related to the greatest length of the arc and is expressed in mm.

EUTIT, s.r.o.

I. N.: 47714930

Stará Voda 196

phone: +420 / 354 789122, +420 / 354 691301

353 01 Mariánské Lázně

fax: +420 / 354 691480

e-mail: eutit@eutit.cz <http://www.eutit.cz>

Table 1 – BENDS (continue)

Indication (d x R x alfa)	d (mm)		D (mm)		t (mm)	alfa		R (mm)
	nominal value	limit tolerance s	nominal value	limit tolerance s		nominal value	* limit tolerances mm	
150/750/15	150,0	+2/-3	200	+3/-2	23-27	15	± 5	750
150/750/30						30		750
150/1000/15						15		1000
150/1000/30						30		1000
150/1500/15						15		1500
150/2000/15						15		2000
150/2500/7,5						7,5		2500
150/3000/7,5						7,5		3000
175/750/15						175,0		+2/-3
175/750/30	30	750						
175/1000/15	15	1000						
175/1000/30	30	1000						
175/1500/15	15	1500						
175/2000/15	15	2000						
175/2500/7,5	7,5	2500						
175/3000/7,5	7,5	3000						
204/750/15	204,0	+2/-3	254,0	+4/-2	23-28		15	
204/750/30						30	750	
204/1000/15						15	1000	
204/1000/30						30	1000	
204/1500/15						15	1500	
204/2000/7,5						7,5	2000	
204/2500/7,5						7,5	2500	
204/3000/7,5						7,5	3000	

* The tolerance of the limiting deviation „alfa“ related to the greatest length of the arc and is expressed in mm.



Cast basalt

Bends, reducers, shaped pieces 90°
and other castings statically casted

P-4

EUTIT, s.r.o.

I. N.: 47714930

Stará Voda 196

phone: +420 / 354 789122, +420 / 354 691301

353 01 Mariánské Lázně

fax: +420 / 354 691480

e-mail: eutit@eutit.cz <http://www.eutit.cz>

Table 1 – BENDS (continue)

Indication (d x R x alfa)	d (mm)		D (mm)		t (mm)	alfa		R (mm)
	nominal value	limit tolerances	nominal value	limit tolerances		nominal value	* limit tolerances mm	
225/750/15	225,0	+2/-4	275,0	+4/-2	23-28	15	± 5	750
225/750/30						30		750
225/1000/15						15		1000
225/1000/30						30		1000
225/1500/15						15		1500
225/2000/7,5						7,5		2000
225/2500/7,5						7,5		2500
225/3000/7,5						7,5		3000
254/750/15	254,0	+2/-4	304,0	+4/-2	23-28	15	± 5	750
254/750/30						30		750
254/1000/15						15		1000
254/1000/30						30		1000
254/1500/15						15		1500
254/2000/7,5						7,5		2000
254/2500/7,5						7,5		2500
254/3000/ 7,5						7,5		3000

* The tolerance of the limiting deviation „alfa“ related to the greatest length of the arc and is expressed in mm.

EUTIT, s.r.o.

I. N.: 47714930

Stará Voda 196

phone: +420 / 354 789122, +420 / 354 691301

353 01 Mariánské Lázně

fax: +420 / 354 691480

e-mail: eutit@eutit.cz <http://www.eutit.cz>

Table 1 – BENDS (continue)

Indication (d x R x alfa)	d (mm)		D (mm)		t (mm)	alfa		R (mm)
	nominal	limit	nominal	limit		nominal	* limit	
	value	tolerances	value	tolerances		value	tolerances mm	
303/750/15						15		750
303/750/30						30		750
303/1000/15						15		1000
303/1500/15	303,0	+3/-5	353,0	+5/-3	23-29	15	± 5	1500 ± 1 %
303/2000/7,5						7,5		2000
303/2500/7,5						7,5		2500
303/3000/7,5						7,5		3000
356/750/15						15		750
356/1000/15						15		1000
356/1500/7,5						7,5		1500
356/2000/7,5	356,0	+3/-5	406	+5/-3	23-30	7,5	± 5	2000 ± 1 %
356/2500/7,5						7,5		2500
356/3000/7,5						7,5		3000
400/750/15						15		750
400/1000/15						15		1000
400/1500/7,5						7,5		1500
400/2000/7,5	400,0	+3/-5	450,0	+5/-3	23-30	7,5	± 5	2000 ± 1 %
400/2500/7,5						7,5		2500
400/3000/7,5						7,5		3000
500/750/15						15		750
500/1000/7,5						7,5		1000
500/1500/7,5						7,5		1500
500/2000/3,75	500,0	+3/-5	550,0	+5/-3	23-30	3,75	± 5	2000 ± 1 %
500/2500/3,75						3,75		2500
500/3000/3,75						3,75		3000

* The tolerance of the limiting deviation „alfa“ related to the greatest length of the bend and is expressed in mm.

In addition to the stated casting other wide assortment according to agreement with customers is manufactured.



Cast basalt

Bends, reducers, shaped pieces 90°
and other castings statically casted

P-4

EUTIT, s.r.o.

I. N.: 47714930

Stará Voda 196

phone: +420 / 354 789122, +420 / 354 691301

353 01 Mariánské Lázně

fax: +420 / 354 691480

e-mail: eutit@eutit.cz <http://www.eutit.cz>

- A 1.** The products are indicated by inside diameter d , radius R and central angle (α).
- A 2.** The mass of the products is calculated from the volume weight of 2960 kgm^{-3} according to the formula $M = 1,623 \cdot 10^{-7} \cdot R \cdot t \cdot (d+t) \cdot \alpha$. This mass is only approximate, because the actual mass can differ within the bend of standardised tolerances for dimensions. (Such an bend which has a radius of $R = 2000 \text{ m}$, a thickness of $t = 25 \text{ mm}$, an external diameter of $d = 254 \text{ mm}$ and a central angle of $\alpha = 7,5^\circ$ has a mass of approximately $M = 17 \text{ kg}$).
- A 3.** Technical requirements for the order:
indication - see tab. 1
- A 4.** The bends are manufactured in dimensional range and tolerances according to tab. 1.
- A 5.** Ovality (out-of-roundness) is defined within the limit tolerances of inside diameter of the bend.
- A 6.** Perpendicularity of front surfaces is defined within limit tolerances of angle α .

1. Common provisions - Catalogue sheet No. E - 01

2. Surface quality

Basalt products must have a clear sound, they must not have defects, which could affect their function during the use determined.

3. At least 95 % of products must not have visible defects, which could affect surface quality of the tiles and they must meet requirements for sampling (principal see EN ISO 10545-1).

EUTIT, s.r.o.

Stará Voda 196

353 01 Mariánské Lázně

I. N.: 47714930

phone: +420 / 354 789122, +420 / 354 691301

fax: +420 / 354 691480

e-mail: eutit@eutit.cz <http://www.eutit.cz>**B. REDUCERS**

Fig. 2

EUTIT, s.r.o.

I. N.: 47714930

Stará Voda 196

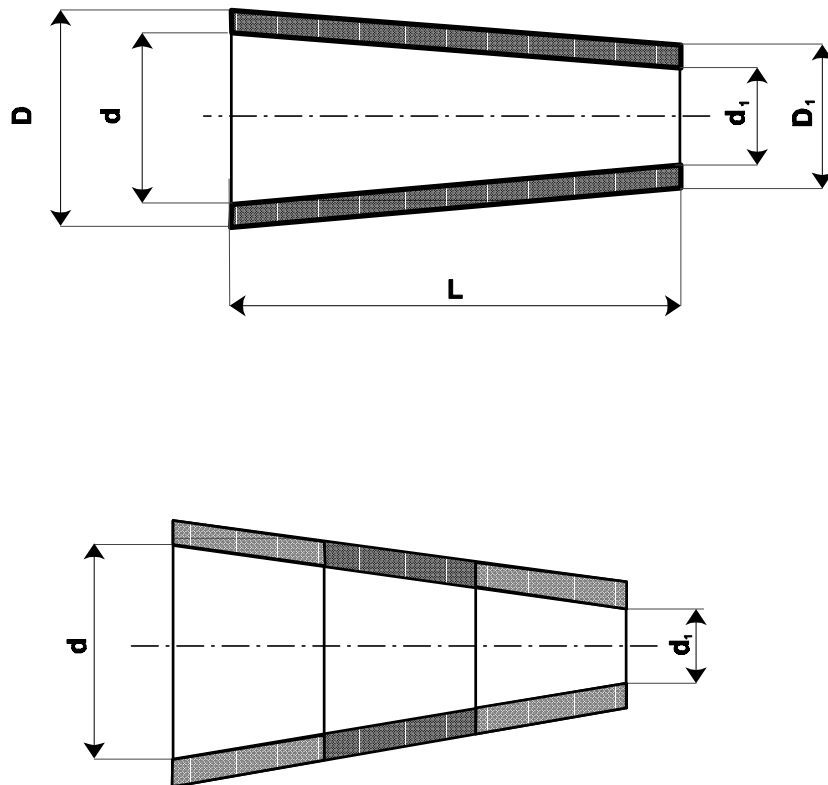
phone: +420 / 354 789122, +420 / 354 691301

353 01 Mariánské Lázně

fax: +420 / 354 691480

e-mail: eutit@eutit.cz <http://www.eutit.cz>**Table 1. DIMENSIONS OF REDUCERS AND THEIR LIMIT TOLERANCES**

Inside diameters and their limit tolerances (mm)				Outside diameters and their limit tolerances (mm)				Lengths and their limit tolerances (mm)	
d		d ₁		D		D ₁		L	
100	+2/-3	82,5	± 2	150	+3/-2	132,5	± 3	150	± 2
125		100		175		150	150		
150		125	+2/-3	200		175	150		
175		150		225		200	+3/-2	150	
204	+2/-4	175		254	+4/-2	225		150	
254		204	+2/-4	304		254	+4/-2	250	
303	+3/-5	254		353	+5/-3	304		250	
356		303		406		353	250		
400		356	+3/-5	450		406	+5/-3	250	± 3
500		400		550		450		500	± 5

Note: The reducer $d = 500$ is always supplied after agreement between manufacturer and customer (subject of the agreement can be e.g. the way of division of the reducer into parts etc.).

In addition to the stated casting other wide assortment according to agreement with customers is manufactured.

B 1. Indication of products:

The reducers cast directly of cast basalt of required dimensions $d = 125$ mm and $d_1 = 100$ mm are indicated

Reducer 125/100 L=150

B 2. Dimensions of the reducers are listed in tab. 1.

B 3. The reducers are manufactured according to dimensional table. As to requirement for reducer with a larger difference of diameters, manufacturer shall supply them assembled from more parts according to table 1.

B 4. The way of assembly of the reducers, as to requirement for a larger difference d and d_1 is shown in the Fig. No. 1.

B 5. Out-of-roundness is defined within limit tolerances and outside diameters.

**Cast basalt****Bends, reducers, shaped pieces 90°
and other castings statically casted****P-4****EUTIT, s.r.o.**

Stará Voda 196

353 01 Mariánské Lázně

I. N.: 47714930

phone: +420 / 354 789122, +420 / 354 691301

fax: +420 / 354 691480

e-mail: eutit@eutit.cz <http://www.eutit.cz>

- B 6.** The deviations of perpendicularity of the front levels from axis of the product are defined within limit tolerances of the length L.
- B 7.** Manufacturer shall indicate numerical values d and d₁ on each reducer.
- B 8.** The mass of reducing sleeves is calculated from the volume weight of cast basalt of 2960 kg m⁻³. This mass can differ from the actual one within the range of standardised tolerances for dimensions.

1. Common provisions - Catalogue sheet No. E - 01

2. Surface quality

Basalt products must have a clear sound, they must not have any defects, which could affect their function for the use determined.

3. At least 95 % of products must not have visible defects, which could affect surface quality of the tiles and they must meet requirements for sampling (principal see EN ISO 10545-1).

EUTIT, s.r.o.

I. N.: 47714930

Stará Voda 196

phone: +420 / 354 789122, +420 / 354 691301

353 01 Mariánské Lázně

fax: +420 / 354 691480

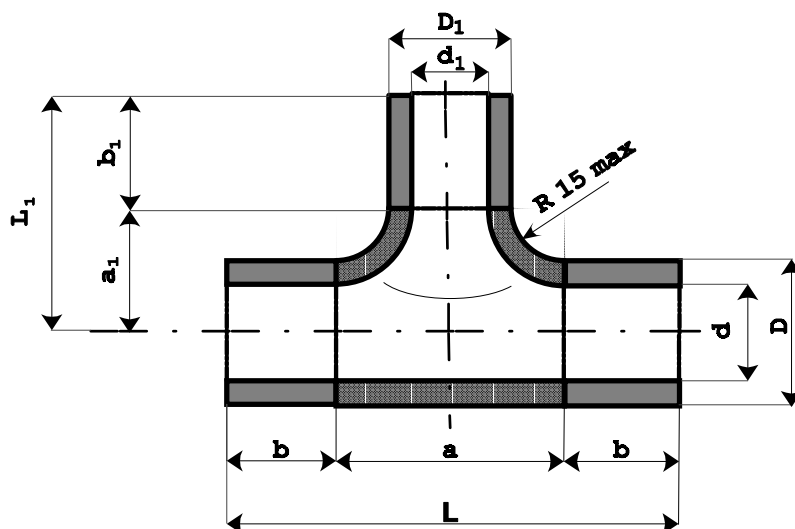
e-mail: eutit@eutit.cz <http://www.eutit.cz>**C. SHAPED PIECES****Fig. 3**

In addition to the stated castings other wide assortment according to agreement with customers is manufactured.



Cast basalt
Bends, reducers, shaped pieces 90°
and other castings statically casted

P-4

EUTIT, s.r.o.

I. N.: 47714930

Stará Voda 196

phone: +420 / 354 789122, +420 / 354 691301

353 01 Mariánské Lázně

fax: +420 / 354 691480

e-mail: eutit@eutit.cz <http://www.eutit.cz>

Table 1. DIAMETR OF SHAPED PIECES AND THEIR WEIGHT

Inside diameters and their limit tolerances (mm)				Outside diameters and their limit tolerances (mm)				t cca [mm]
d		d ₁		D		D ₁		
82,5	± 2	82,5	± 2	132,5	± 3	132,5	± 3	25
100	+ 2/-3	82,5	± 2	150	+3/-2	132,5	± 3	
		100	± 3			150	+ 3/-2	
125	+2/-3	82,5	± 2	175	+3/-2	132,5	± 3	
		100	+2/-3			150	+3/-2	
		125	+2/-3			175	+3/-2	
150	+2/-3	100	+2/-3	200	+3/-2	150	+3/-2	
		125	+2/-3			175	+3/-2	
		150	+2/-3			200	+3/-2	
175	+2/-3	125	+2/-3	225	+3/-2	175	+3/-2	
		150	+2/-3			200	+3/-2	
		175	+2/-3			225	+3/-2	
204	+2/-4	150	+2/-3	254	+4/-2	200	+3/-2	
		175	+2/-3			225	+3/-2	
		204	+2/-4			254	+4/-2	
254	+2/-4	175	+2/-3	304	+4/-2	225	+3/-2	
		204	+2/-4			254	+4/-2	
		254	+2/-4			304	+4/-2	
303	+3/-5	204	+2/-4	353	+3/-5	254	+4/-2	
		254	+2/-4			304	+4/-2	
		303	+3/-5			353	+5/-3	
356	+3/-5	254	+2/-4	406	+5/-3	304	+4/-2	
		303	+3/-5			353	+5/-3	
		356	+3/-5			406	+5/-3	
400	+3/-5	303	+3/-5	450	+5/-3	353	+5/-3	
		356	+3/-5			406	+5/-3	
		400*)	+3/-5			450	+5/-3	
500	+3/-5	356*)	+3/-5	550	+5/-3	406	+5/-3	
		400*)	+3/-5			450	+5/-3	
		500*)	+3/-5			550	+5/-3	

***) Note:** The shaped pieces are only supplied after a mutual agreement on work between manufacturer and customer (subject of the agreement can be e.g. size of limit tolerances of the diameter d, d₁, D, D₁, division of the shaped piece into smaller parts etc.).



Cast basalt

Bends, reducers, shaped pieces 90°
and other castings statically casted

P-4

EUTIT, s.r.o.

I. N.: 47714930

Stará Voda 196

phone: +420 / 354 789122, +420 / 354 691301

353 01 Mariánské Lázně

fax: +420 / 354 691480

e-mail: eutit@eutit.cz

<http://www.eutit.cz>

Table 2. LENGTH OF PRODUCTS AND THEIR LIMIT TOLERANCES

Diameters (mm)		Lendths and their limit tolerances (mm)												
d	d ₁	L		L ₁		a		a ₁		b		b ₁		
82,5	82,5	450	± 2	225	± 2	-	-	-	-	-	-	-	-	
100	82,5	475		237,5		-	-	-	-	-	-	-	-	-
	100	500		250		-	-	-	-	-	-	-	-	-
125	82,5	500	± 2	250	± 2	-	-	-	-	-	-	-	-	
	100	525		262,5		-	-	-	-	-	-	-	-	-
	125	550		275		-	-	-	-	-	-	-	-	-
150	100	550	± 2	275	± 2	-	-	-	-	-	-	-	-	
	125	575		287,5		275	± 2	137,5	± 2	147	± 2	147	± 2	
	150	600		300		300		150		147				
175	125	600	± 2	300	± 2	300		± 2		150		± 2		147
	150	625		312,5		325	162,5		147	147				
	175	650		325		350	175		147	147				
204	150	650	± 2	325	± 2	350	± 2	175	± 2	147	± 2	147		
	175	675		337,5		375		187,5		147		147		
	204	700		350		400		200		147		147		
254	175	725	± 2	362,5	± 2	325	± 2	312,5	± 2	197	± 2	147		
	204	750		375		350		225		197		147		
	254	800		400		400		200		197		197		
303	204	800	± 3	400	± 3	400	± 3	250	± 3	197	± 3	147		
	254	850		425		450		225		197		197		
	303	900		450		500		250		197		197		
356	254	900	± 3	450	± 3	400	± 3	250	± 3	247	± 3	197		
	303	950		475		450		275		247		197		
	356	1000		500		500		250		247		247		
400	303	1000	± 4	500	± 4	500	± 4	300	± 3	247	± 3	197		
	356	1050		525		550		275		247		247		
	400	1100		550		600		300		247		247		
500	356	1200	± 4	600	± 4	500	± 4	350	± 3	347	± 3	247		
	400	1250		625		550		375		347		247		
	500	1400		700		650		350		372		347		

Note: Limit tolerance of total length L and L₁ corresponds with the sum of limit tolerances of the body and inserts (a, a₁, b, b₁).

EUTIT, s.r.o.

I. N.: 47714930

Stará Voda 196

phone: +420 / 354 789122, +420 / 354 691301

353 01 Mariánské Lázně

fax: +420 / 354 691480

e-mail: eutit@eutit.cz <http://www.eutit.cz>

In addition to the stated casting other wide assortment according to agreement with customers is manufactured.

C 1. Indication of products:

Shaped piece T 90°C with the same diameters of holes of cast basalt, d and d_1 equal to 125 mm, is indicated:

$$\textit{Shaped piece T 125/125} \quad L = 550 \quad L_1 = 275$$

Shaped piece T 90°C with different diameters of holes of cast basalt, $d = 125$ mm and $d_1 = 100$ mm, is indicated:

$$\textit{Shaped piece T 125/100} \quad L = 525 \quad L_1 = 262,5$$

C 2. Dimensions of products are stated in the tables 1 and 2.**C 3.** Shaped pieces are manufactured according to dimensional tables. Up to diameter 150/100 the shaped pieces are manufactured as a whole unit. Shaped pieces of a larger diameter are assembled from four parts (see scheme of product). They are always manufactured as a whole unit.**C 4.** Out-of-roundness is defined within limit tolerances of inside and outside diameters.**C 5.** Deviations of perpendicularity of front surfaces from axis of the product are defined within limit tolerances of length.**C 6.** d and d_1 are indicated on each shaped piece.**C 7.** The mass of shaped pieces is calculated from the volume weight of cast basalt of 2960 kg m^{-3} . This mass can differ from the actual one within the range of standardised tolerances for dimensions.**1.** Common provisions - Catalogue sheet No. E - 01**2.** Surface quality

Cast basalt products must have a clear sound, they must not have defects, which could affect their function during the use determined.

3. At least 95 % of products must not have visible defects, which could affect surface quality of the tiles and they must meet requirements for sampling (principal see EN ISO 10545-1).

EUTIT, s.r.o.

Stará Voda 196

353 01 Mariánské Lázně

I. N.: 47714930

phone: +420 / 354 789122, +420 / 354 691301

fax: +420 / 354 691480

e-mail: eutit@eutit.cz <http://www.eutit.cz>

D. SHAPED PIECES FOR SURFACE AND SUBSURFACE SEWERAGE SYSTEMS

Shaped pieces for surface and subsurface sewers are intended for internal lining of sewers, namely for:

- ♦ circular-shaped sewers - see Fig. and Table 4 - Czech standard ČSN 75 6101 as from August 1995
- ♦ egg-shaped sewers (b:h=2:3) - see Fig. and Table 5 - ČSN 75 6101
- ♦ mouth-shaped sewers (b:h=2:1.268) - see Fig. and Table 6 - ČSN 75 6101
- ♦ egg-shaped sewers of the Prague normal - see Fig. and Table 7 - ČSN 75 6101
- ♦ and also other shapes and sizes of sewers than specified in ČSN 75 6101- in accordance with customer's individual requirements.

On the basis of customer's requirements there is also possible to deliver the basaltic shaped pieces only for a part of particular sewer profile. See example shown in Figure 1.

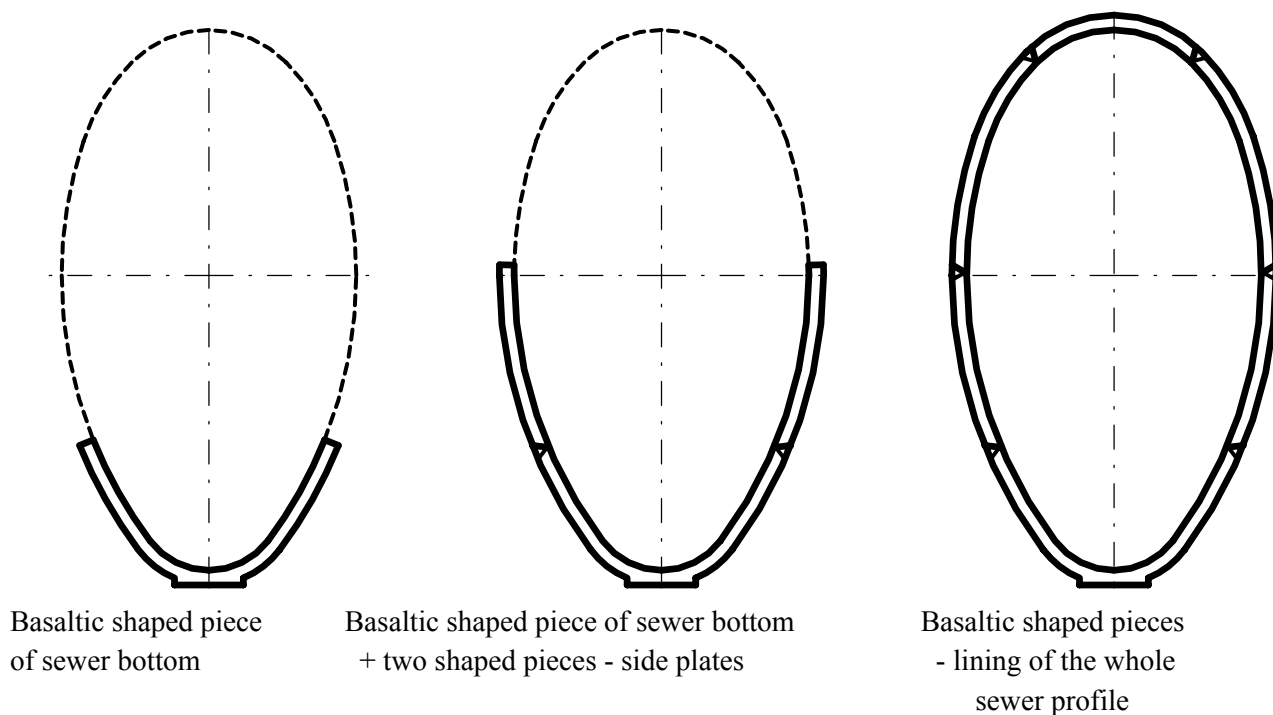

Figure 1

EUTIT, s.r.o.

Stará Voda 196

353 01 Mariánské Lázně

I. N.: 47714930

phone: +420 / 354 789122, +420 / 354 691301

fax: +420 / 354 691480

e-mail: eutit@eutit.cz <http://www.eutit.cz>

On the basis of customer's requirements it is possible to make a lock between individual basaltic shaped pieces. The shape of such lock is shown in Figure 2.

There is also possible to make a conical opening in shaped pieces - side plates. These openings serve for anchoring of side plates into the sewer supporting concrete.

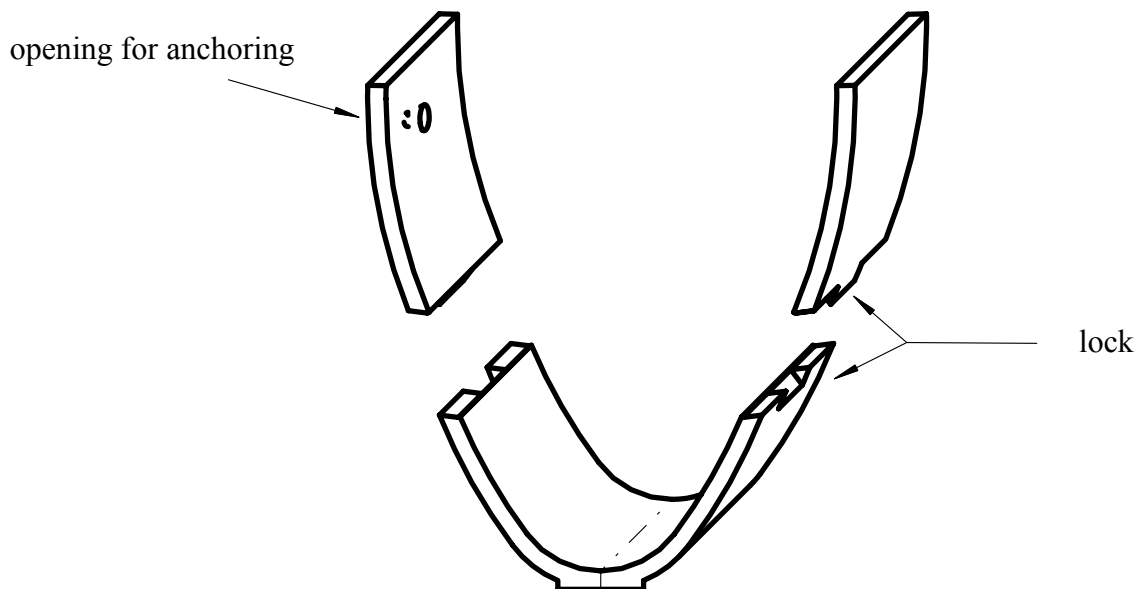
**Figure 2**

1. Outside of shaped pieces is provided with grooving for better adhesion to the base.
2. Size, shape and production tolerances have to be always agreed on with the manufacturer.
3. Common provisions - Catalogue Sheet No. E-01.
4. As a rule, basaltic shaped pieces for surface-water sewers are delivered with 30 mm wall thickness.
5. The shaped piece weight is calculated from volume weight 2960 kg.m^{-3} . This mass is only approximate, because the actual mass can differ within the bend of standardised tolerances for dimensions. Generally, weight of one shaped piece is less than 30 kg.
6. Basaltic products must not contain defects that would influence their behaviour during the intended usage.
7. At least 95 % of products must not have visible defects, which could affect surface quality of the tiles and they must meet requirements for sampling (principal see EN ISO 10545-1).



EUTIT, s. r. o.

I. N.: 47714930

Stará Voda 196

Telephone.: +420 / 354 789122, +420 / 354 691301

353 01 Mariánské Lázně

Fax: +420 / 354 691480

e-mail: eutit@eutit.cz

<http://www.eutit.cz>

Besides the castings listed in this catalogue sheet in appendixes P1 – P5, a wide range of other products is manufactured, from metallic-mould castings to sand-mould castings (various shaped pieces, radial tables, tiles with a hole etc.).

1. The shape, size, and tolerances for dimensions of basalt products have to be agreed upon with the manufacturer.
2. Common provisions – Catalogue sheet No. E – 01.
3. Surface finish
Basalt products must have clear sound, and cannot have defects which could have negative influence on their function in the relevant application.
4. The mass of castings is calculated from the volume weight of 2960 kg m^{-3} . This mass can differ from the actual mass within the range of standardised tolerances for dimensions. In case the products are grooved, the mass is also influenced by the size of grooves and the method of grooving.
5. At least 95 % of the products must not have visible defects which could have negative influence on the surface finish and they have to meet the requirements on sampling (principal see EN ISO 10545-1).